

Steel Strapping Tensioner

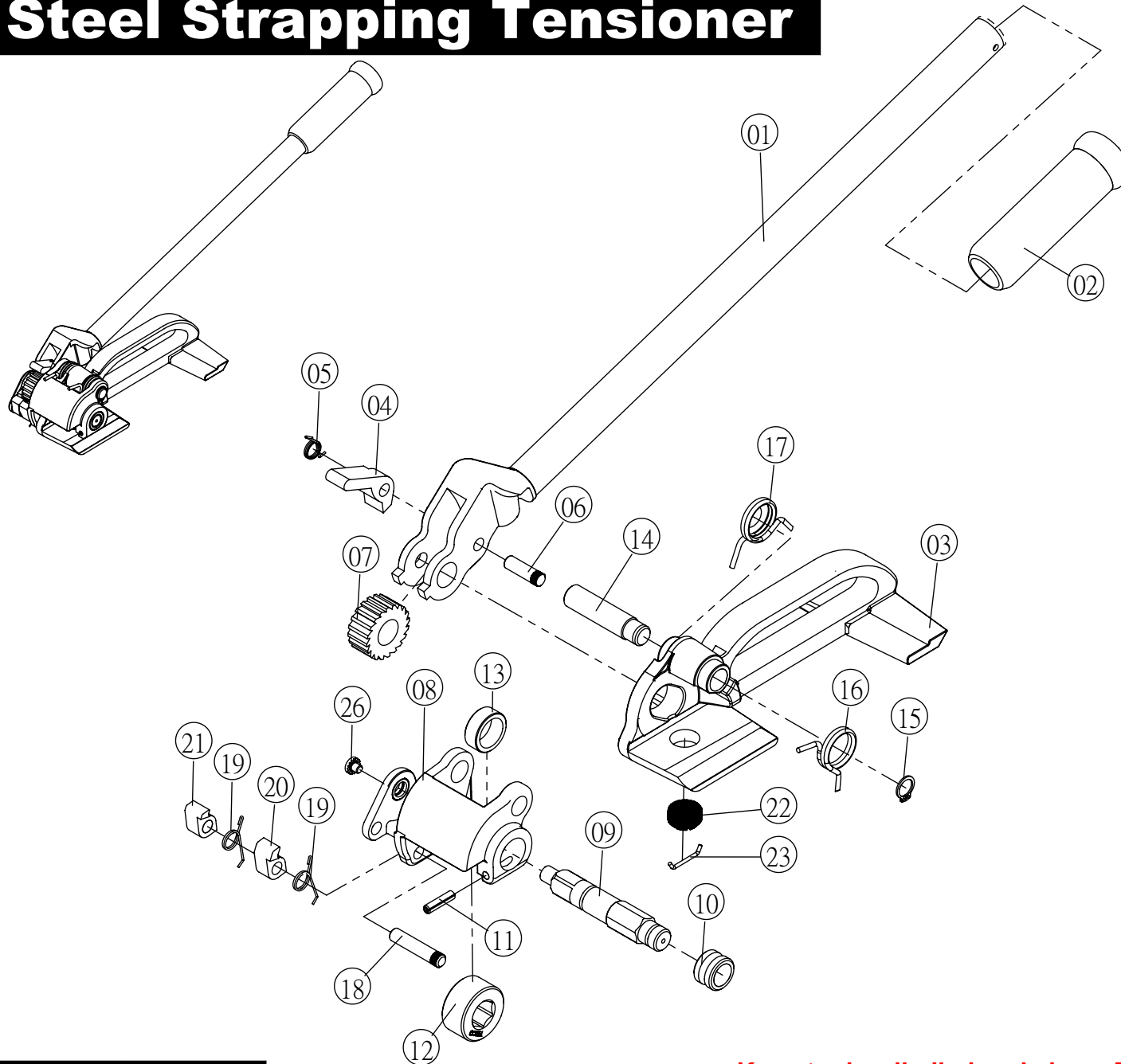

Part No.	Part Name	QTY
01	Handle	1
02	Grip	1
03	Base	1
04	Handle Pawl	1
05	Handle Pawl Spring	1
06	Handle Pawl Pin	1
07	Ratchet Gear	1
08	Support Frame	1
09	Shaft	1
10	Bushing	1
11	Roll Pin	1
12	Feedwheel	1
13	Strap Spacer	1
14	Support Pin	1
15	Retaining Ring	1
16	Retaining Support Spring	1
17	Feedwheel Support Spring	1
18	Retaining Pawl Pin	1
19	Pawl Spring	2
20	Long Pawl	1
21	Short Pawl	1
22	Clutch Plug	1
23	Wire	1
26	Screw	1

Steel Strapping Tensioner

OPERATING INSTRUCTIONS

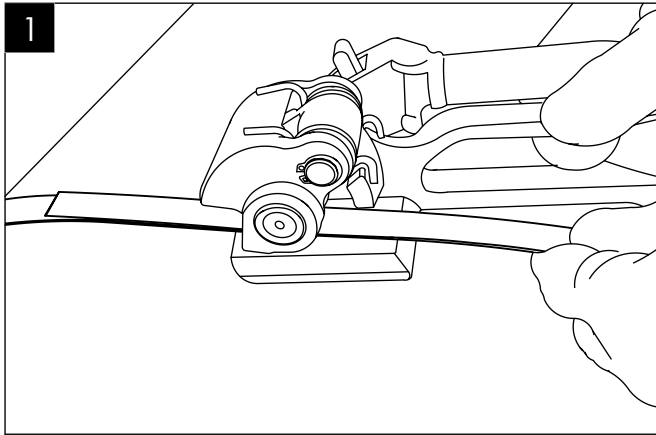

1 Squeeze the handle to lift support frame. While in this position, move the tool and slide the strap under the feedwheel. The strapping material is now locked and ready to be tightened.

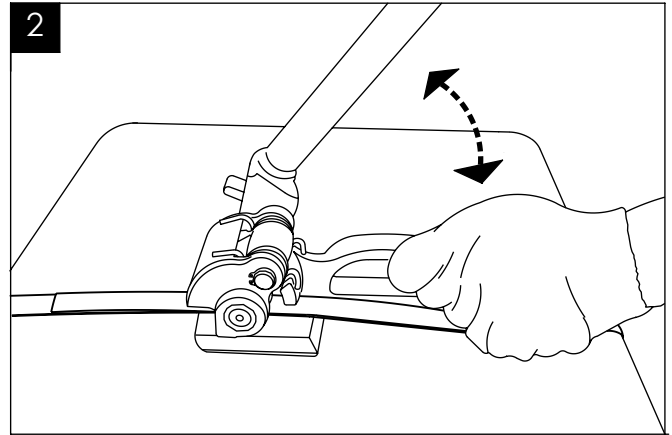

2 Hold the tool with your left hand and pump the handle until the straps are sufficiently tight. Don't over-tighten the straps as damage may occur to the tool and object being strapped.

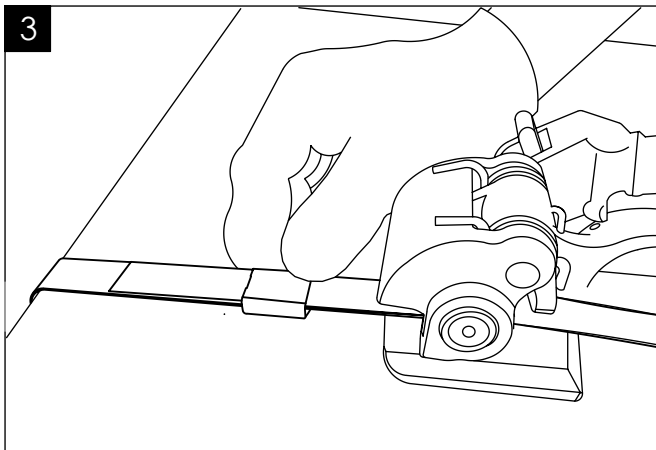

3 Press the handle pawl down so that the handle can be released.

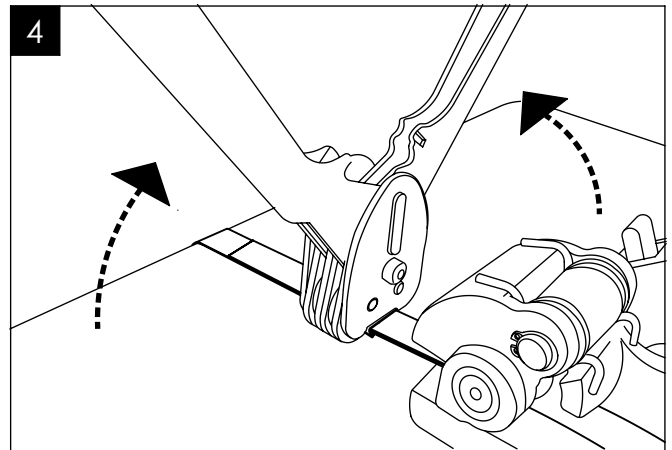

4 Open the sealer fully open position, put the sealer on the top of the seal, press the sealer handle together to fully crimp the seal, then remove the sealer.

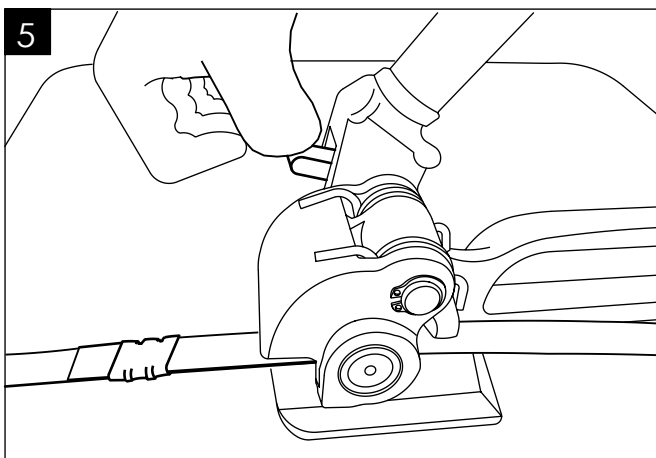

5 Place the seal open side down over both straps in front of the tool.

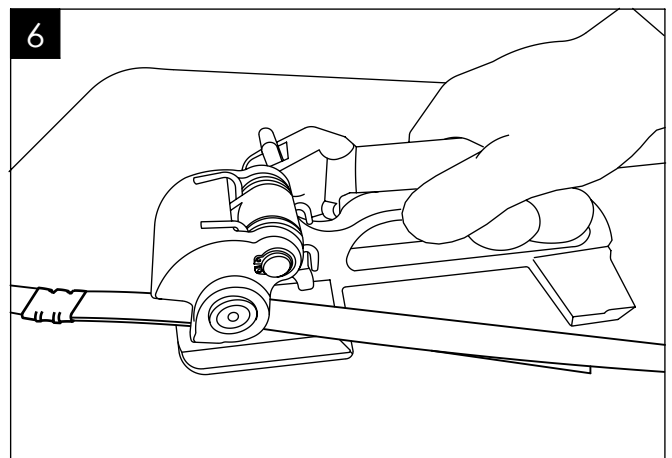

6 Compress down the handle to lift the feedwheel. Slide the tool away from the strapping material. Cut excess strap with a steel strapping cutter.